

Illustration - Type - E

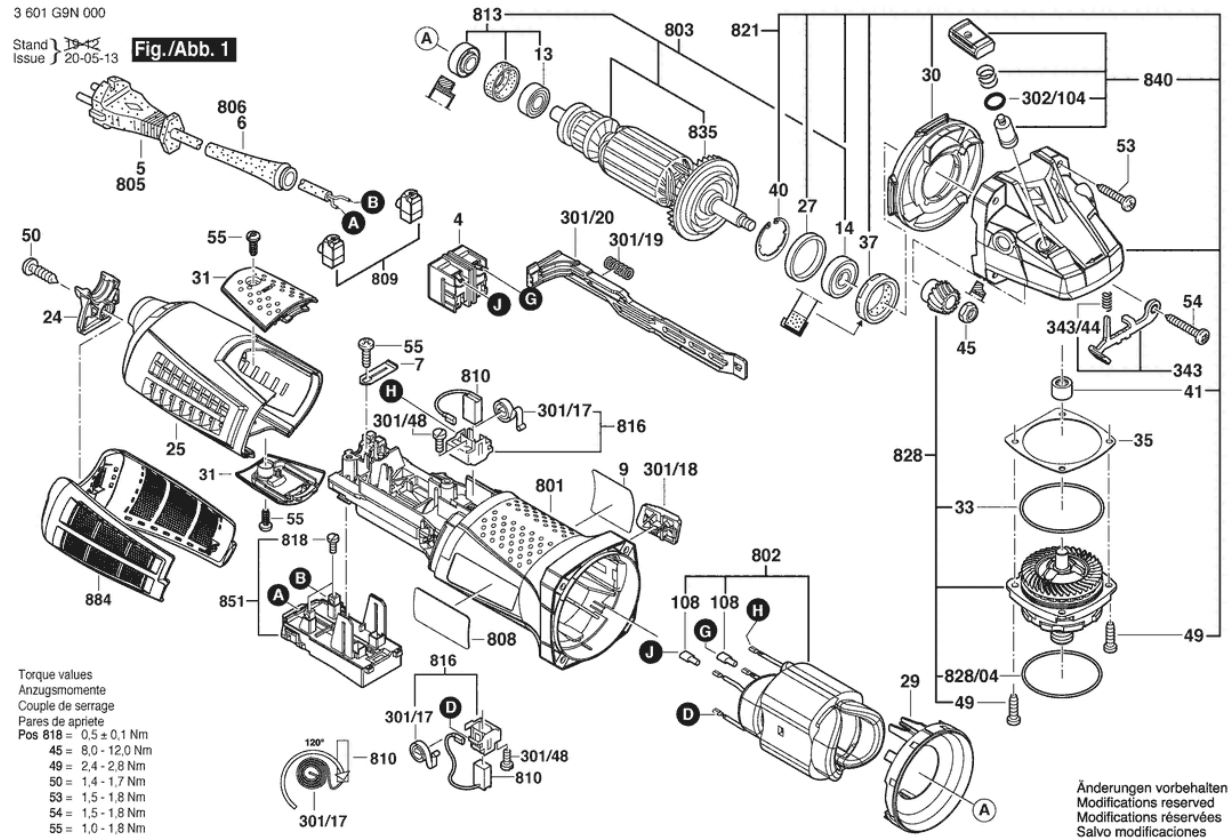
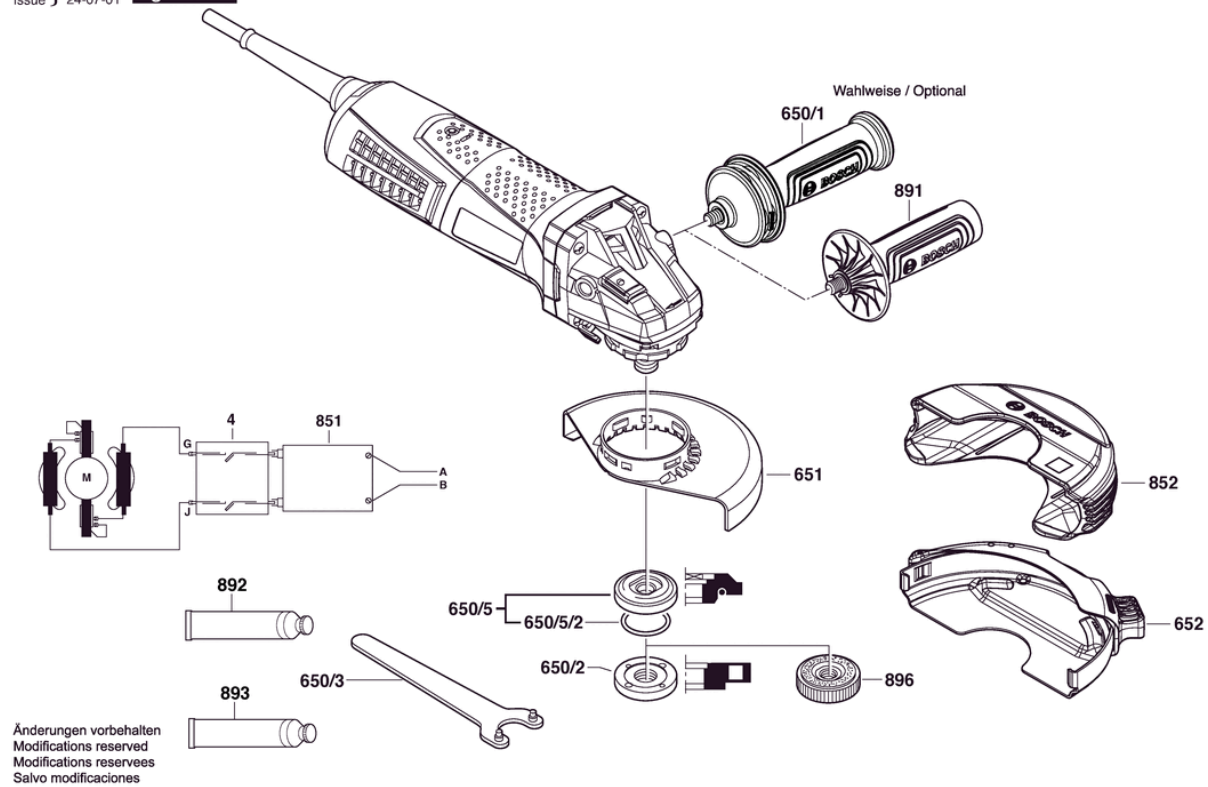

Illustration - Type - E

3 601 G9N 000

Stand } 23-06
Issue } 24-07-01

Fig./Abb. 2



Spare parts list

Item	Part Number	Description	Illustration
4	1 607 200 35A	Switch	1
6	1 600 703 043	Grommet	1
7	1 601 302 017	Fastening Clamp	1
9	1 601 11C 0EE	Manufacturer's nameplate GWS 19-150 CI	1
13	2 600 905 032	Ball Bearing 7X19X6	1
14	1 600 905 032	groove ball bearing 8X22X7	1
24	1 605 500 274	Cover	1
25	1 605 500 276	Housing Cover	1
27	1 600 206 025	Rubber Ring	1
29	1 600 591 047	Air-Deflector Ring	1
30	1 600 591 048	Air Distributor	1
31	1 600 A01 M0M	Brush-Cover	1
33	1 600 210 035	O-Ring 46,0X1,1 MM	1
35	1 600 136 013	Shim 0,1 MM THICK	1
35	1 600 136 014	Shim 0,2 MM THICK	1
35	1 600 136 015	Shim 0,3 MM THICK	1
35	1 600 136 020	Shim 0,15 MM THICK	1
37	1 600 290 016	Rotary shaft lip seal	1
40	1 600 119 011	Retaining clip	1
41	1 600 200 029	Plain bearing	1
45	1 603 300 016	Hex Nut M7, SW10	1
49	1 603 435 08X	Thread-forming tap. Screw M4X16-ST W/ PRECOTE 85-3	1
50	2 603 490 023	Torx Oval-Head Screw 4X20	1
53	1 603 435 078	Torx Oval-Head Screw	1
54	1 603 414 026	Torx Oval-Head Screw 4X30	1
55	2 603 490 021	Torx Oval-Head Screw 4X12	1
108	1 600 712 030	Insulating Part	1
301/17	1 604 652 021	Spiral Spring	1
301/18	1 602 026 091	Switch Handle	1
301/19	1 604 611 031	Compression Spring	1
301/20	1 602 319 026	Adjusting Slide	1
301/48	1 613 435 034	Lens Head Screw 3X10 ST	1
302/104	1 600 210 044	O-Ring 4,5X1,0 MM BLUE	1
343	1 607 000 742	Catch Lever	1

Spare parts list

Item	Part Number	Description	Illustration
343/44	1 604 611 042	Compression Spring	1
801	1 607 000 CY2	Motor Housing	1
802	1 604 220 53W	Field assembly 230V	1
803	1 600 A00 D2P	Armature With Fan 230V	1
805	1 607 000 392	Power supply cord EU 4,15M 2 X 1,0MM H07 RN-F	1
808	1 601 11A 97N	Nameplate	1
809	1 607 000 D9C	Seal	1
810	1 607 000 V37	Carbon-Brush Set	1
813	1 607 000 V38	groove ball bearing	1
816	1 607 000 V43	Brush Holder	1
818	1 607 000 V42	Pan head screw	1
821	1 607 000 V40	Gear Housing	1
828	1 607 000 D63	Bearing Flange	1
828/04	3 600 210 109	O-Ring 47,0X1,5 MM	1
835	1 606 610 132	Fan	1
840	1 607 000 V41	Push-Button	1
851	1 607 000 DA7	Speed governor	1
884	1 600 A01 534	Filter	1
650/1	1 602 025 0A0	Auxiliary Handle	2
650/2	1 603 345 043	Round Nut M14	2
650/3	1 607 950 052	Pin-Type Face-Wrench	2
650/5	2 605 703 014	Clamping Flange Ø22,3XØ42 MM	2
650/5/2	1 600 210 039	O-Ring 20,35X1,78 MM	2
651	1 600 A02 5XT	Protective Cover	2
652	1 600 A02 2AU	Protective Cover	2
891	1 602 025 09T	Auxiliary Handle	2
892	1 615 430 017	Grease Tube 225 ML	2
893	1 615 430 020	Grease Tube 225 ML	2
896	1 600 A01 6PP	Fast Locking Flange	2